

VDIC NAND FLASH MEMORY

VDNF16G08XS50XX1V25 USER MANUAL

Version : A1

Document NO. : ORBITA/SIP-VDNF16G08XS50XX1V25-USM-01

Zhuhai Orbita Aerospace Science & Technology Co. , Ltd.

Add: Orbita Tech Park, NO.1 Baisha Road, Tangjia Dong ` an,

Zhuhai, Guangdong, China 519080

Tel: +86-756-3391979 Fax: +86-756-3391980

Contents

1	Description	1
2	Features	1
3	Block Diagram.....	2
4	Pin Descriptions-sop-50	2
5	Electrical Specifications	4
5.1	Absolute Maximun Ratings	4
5.2	Recommended DC Operating Conditions	4
5.3	DC Characteristics and Operating Conditions.....	4
6	Typical Application	5
7	ORDERING INFORMATION	6
8	PACKAGE DIMENSIONS	7
9	REVISION HISTORY	8

VDIC-NAND Flash Memory

HIGH-SPEED 3.3V 2G × 8bit

1 Description

The VDNF16G08XS50XX1V25 is a 16G-bit NAND Flash Memory device and operates Voltage at 3.3V.

This device contains 1 chip. The chip is offered in 2Gx8bit format and can be operated independently and simultaneously by software.

This VDNF16G08XS50XX1V25 device include an asynchronous data interface for high-performance I/O operations .These devices use a highly multiplexed 8-bit bus (DQx) to transfer commands, address, and data. There are five control signals used to implement the asynchronous data interface: #CE, CLE, ALE, #WE, and #RE. Additional signals control hardware write protection (#WP) and monitor device status (#R/B).

This hardware interface creates a low pin-count device with a standard pin out that remains the same from one density to another, enabling future upgrades to higher densities with no board redesign

The VDNF16G08XS50XX1V25 provides the most cost-effective solution for the solid state application market and is an optimum solution for large nonvolatile storage applications such as solid state data storage and advanced embedded control applications.

2 Features

- Voltage Supply
 - 3.3V device: 2.7 ~ 3.6 V
- Organization
 - page size x8:4320 bytes(4096+224 bytes)
 - Block size:128 pages(512K+28K bytes)
 - Plane size: 2 Planesx2048 blocks per Plane
 - Device size:16G:4096 block
- Asynchronous I/O performance
 - UP to asynchronous timing mode 4
 - 'RC/^WC:25ns (MIN)
- Array performance
 - Read page : 25μs(Max.)
 - Program time : 230μs(Typ.)
 - Block Erase Time : 700μs (Typ.)
- First block (block address 00h) is valid when shipped from Factory. for minimum required ECC, see Error

Management

- RESET(FFh) required as first command after power on
- Operation status byte provides software method for detecting
 - Operation completion
 - Pass/fail condition
 - Write-protect status
- Copyback operations supported within the plane from which data is read
- Package
 - SOP-50

3 Block Diagram

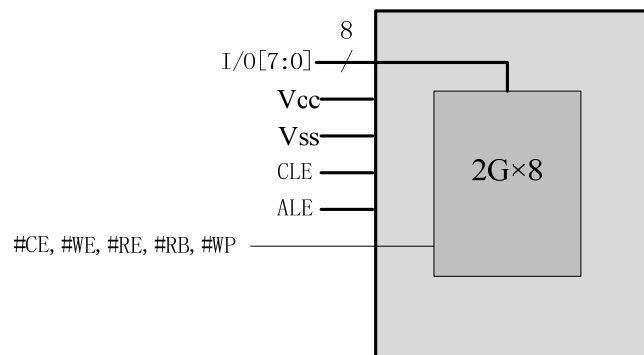

Figure 1 Block diagram

4 Pin Descriptions-sop-50

Pin Id	Pin #		Pin Id
NC	1	50	NC
NC	2	49	NC
NC	3	48	NC
NC	4	47	NC
NC	5	46	NC
NC	6	45	I/O7
NC	7	44	I/O6
#RB	8	43	I/O5
#RE	9	42	I/O4
#CE	10	41	NC
NC	11	40	NC
NC	12	39	VCC
VCC	13	38	VCC
VSS	14	37	VSS
NC	15	36	VSS
NC	16	35	VSS
CLE	17	34	NC
ALE	18	33	I/O3
#WE	19	32	I/O2
#WP	20	31	I/O1
NC	21	30	I/O0
NC	22	29	NC
NC	23	28	NC
NC	24	27	NC
NC	25	26	NC

Figure 2 Pin configuration

Table 1: Pin description

Name	Function
I/O0~I/O7	DATA INPUTS/OUTPUTS The DQ pins are used to input command, address and data, and to output data during read operations. The DQ pins float to high-z when the chip is deselected or when the outputs are disabled.
CLE	COMMAND LATCH ENABLE The CLE input controls the activating path for commands sent to the command register. When active high, commands are latched into the command register through the DQ ports on the rising edge of the #WE signal.
#CE	CHIP ENABLE. When #CE is Low, the command input cycle becomes valid. When #CE is High, all inputs are ignored.
ALE	ADDRESS LATCH ENABLE The ALE input controls the activating path for address to the internal address registers. Addresses are latched on the rising edge of #WE with ALE high.
#RE	READ ENABLE The #RE input is the serial data-out control, and when active drives the data onto the DQ bus. Data is valid t_{REA} after the falling edge of #RE which also increments the internal column address counter by one.
#WE	WRITE ENABLE The #WE input controls writes to the DQ port. Commands, address and data are latched on the rising edge of the #WE pulse.
#WP	WRITE PROTECT The #WP pin provides inadvertent write/erase protection during power transitions. The internal high voltage generator is reset when the #WP pin is active low.
#RB	READY/BUSY OUTPUT The #R/B output indicates the status of the device operation. When low, it indicates that a program, erase or random read operation is in progress and returns to high state upon completion. It is an open

Name	Function
	drain output and does not float to high-z condition when the chip is deselected or when outputs are disabled.
VCC	POWER.
VSS	GROUND

5 Electrical Specifications

5.1 Absolute Maximum Ratings

Table 2:Absolute Maximum Ratings

Characteristics	Symbol	Maximum ratings	Unit
Supply Voltage relative to V _{SS}	V _{CC}	-0.6 ~ +4.6	V
Voltage on any Pin relative to V _{SS}	V _{IN}	-0.6 ~ +4.6	V
Power Dissipation	P _D	1.0	W
Operating Temperature Range	T _{OPR}	-55 ~ +125	°C
Storage Temperature Range	T _{STG}	-65 ~ +150	°C

5.2 Recommended DC Operating Conditions

Table 3:Recommended DC Operating Conditions

Parameter	Symbol	Min	Typ	Max	Unit
V _{CC} Supply voltage	V _{CC}	2.7	3.3	3.6	V
Input high voltage	V _{IH}	V _{CC} ×0.8	—	V _{CC} +0.3	V
Input low voltage	V _{IL}	-0.3	—	0.2×V _{CC}	V

5.3 DC Characteristics and Operating Conditions

Table 4:DC And Operating Characteristics

Parameter	Symbol	Test Conditions	Min	Max	Unit
Low Level Output Voltage	V _{OL}	V _{CC} =2.7V , I _{OL} =2.1 mA	-	0.4	V
High Level Output Voltage	V _{OH}	V _{CC} =2.7V , I _{OH} =-0.4mA	2.4	-	V

6 Typical Application

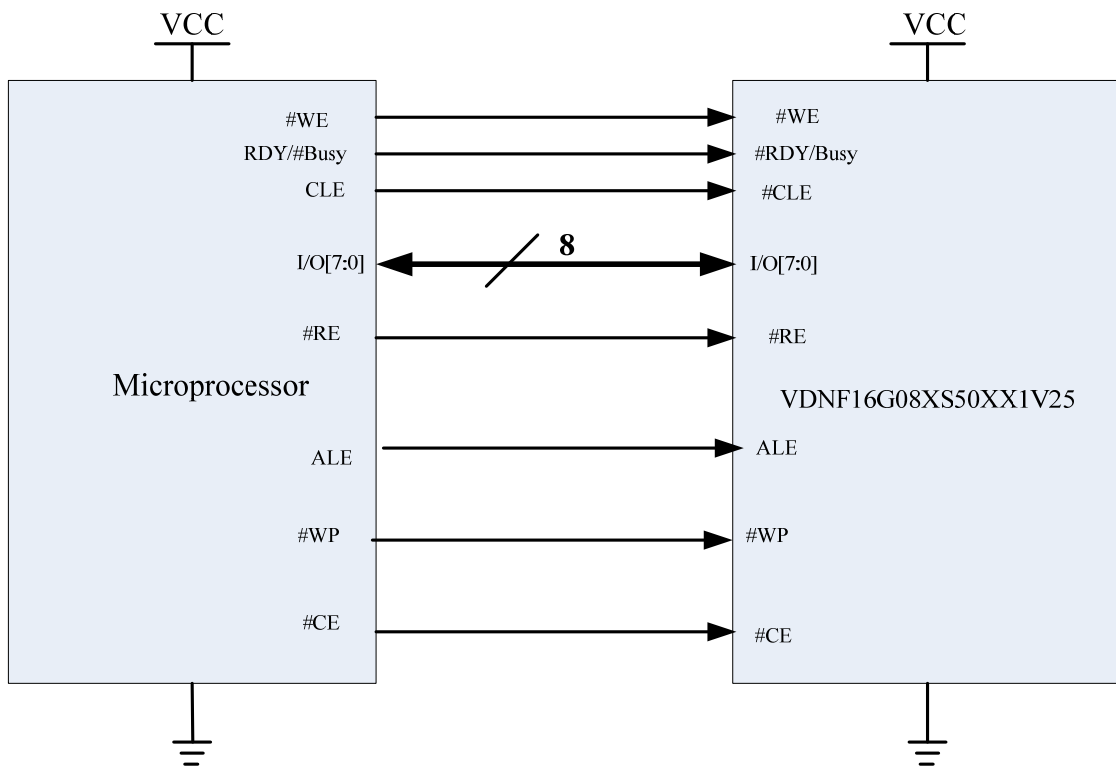

Figure 3 Typical application

7 ORDERING INFORMATION

1	2	3	4	5	6	7	8	9	10	11	12	13
<u>VD</u>	<u>NF</u>	<u>16G</u>	<u>08</u>	<u>X</u>	<u>S</u>	<u>50</u>	<u>X</u>	<u>X</u>	<u>1</u>	<u>V</u>	<u>25</u>	-
VDIC												
NAND FLASH												
Capacity: 16G bit												
Bus Width: 8 bit												
R= Radiation Data Tested; V= Generic Radiation Data Available												
Package: SOP												
Pin Quantity: 50 Pin												
Temperature: E=0~+70℃;I=-40~+85℃;M=-55~+125℃												
Quality: E= Sample; B= Industry; M=Military; S= Space												
Stacking Layer: 1 layer												
Power Supply : 3.3V												
Speed: 25ns												
Version: First Version												

Table 5:Part Information

Part Number	Capacity (bit)	Bus Width (bit)	Radiation			Packaging	Temperature (°C)
			TID ¹	SEL ²	SEU ³		
VDNF16G08VS50EE1V25	16G	08	-	-	-	SOP50	0 ~ +70
VDNF16G08VS50IB1V25	16G	08	-	-	-	SOP50	-40 ~ +85
VDNF16G08VS50MM1V25	16G	08	-	-	-	SOP50	-55 ~ +125
VDNF16G08RS50MS1V25	16G	08	>60	>60	1.3	SOP50	-55 ~ +125

¹ TID: Total Dose (Krad(Si))

² SEL: LET Threshold (Mev.cm²/mg)

³ SEU:SEU Threshold (Mev.cm²/mg)

8 PACKAGE DIMENSIONS

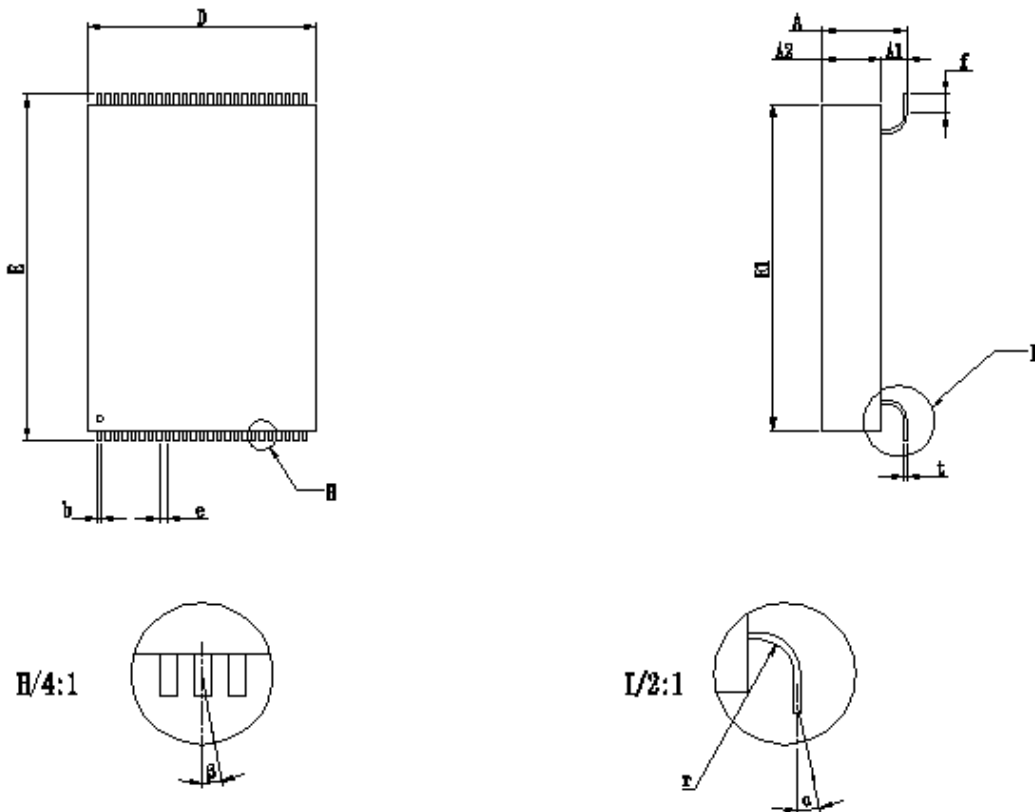

Figure 4 Package dimensions

Table 6 Dimensions information

	Min	Max
A	4.30	5.00
A2	3.10	3.70
D	13.30	13.70
E	19.80	20.20
E1	18.80	19.20
f	1.20	
b	0.25	
e	0.50	
r	1.00	
t	0.20	
α	$\leq 3^\circ$	
β	$\leq 3^\circ$	
NOTE: 1. Unit: mm 2. A1=A - A2		

9 REVISION HISTORY

Table 7 Revision history

Revision	Date	Description of Change
A0	Sep 3,2018	First Created
A1	Mar 19,2020	Update TID and SEE